



# Proven Performance and Reliability

## SRU Rotary Lobe Pump

### Application

The SRU range of rotary lobe pumps has been designed for use on wide ranging applications within the Brewing, Dairy, Food, Pharmaceutical and Chemical industries. The SRU pump can handle low to high viscosity media, is suitable for CIP (Cleaning In Place), and conforms to USA 3A Sanitary Standard. The characteristic smooth, low shear pumping action is ideal for products such as creams, gels, emulsions, aerated mixtures, delicate cells and organic solids in suspension.

The SRU range is compact in size and highly efficient, capable of flow rates up to 466 gpm and pressures up to 290 psi. The new improved modular design provides for greater application flexibility and cost effective easy maintenance.

### Standard Design

#### Pump Gearbox

The SRU pump with its conventional lobe pump design concept has a robust cast iron gearbox, which provides maximum shaft rigidity and easy oil seal replacement. The SRU range in series 1-4 has a universal gearbox design. This gives the flexibility of mounting pumps with the inlet and outlet ports in either a vertical or horizontal plane by changing the foot position. The SRU range in series 5 & 6 has dedicated gearbox castings, which also allows the inlet and outlet ports to be in either the vertical or horizontal plane. A quality epoxy paint system is used on the gearbox exterior for optimum protection against natural and corrosive elements.

#### Pumphead Construction

The SRU in standard specification has sanitary design full bore inlet and outlet ports to International Standards, maximizing inlet and outlet port efficiency and NPSH characteristics. Enlarged diameter and rectangular ports are also available to handle very high viscosity products.

The SRU in standard specification has tri-lobe rotors with the option of bi-lobe rotors for handling fluids containing large delicate solids. All rotors are available in three temperature ratings allowing the pump to be operated at maximum process temperatures of 158°F, 266°F and 392°F for both fluid pumped and CIP.



SRU Rotary Lobe Pump

### Maximum Solid Size Capability

	Max. size of spherical solids (in.)	
	Bi-lobe rotors	Tri-lobe rotors
SRU1N	.31	.24
SRU1W	.31	.24
SRU2N	.31	.24
SRU2W	.51	.35
SRU3N	.51	.35
SRU3W	.63	.43
SRU4N	.63	.43
SRU4W	.87	.59
SRU5N	.87	.59
SRU5W	1.06	.71
SRU6/N	1.06	.71
SRU6W	1.46	.94

### Materials of Construction

Pump gearbox – high quality grey cast iron.

Pumphead – product wetted components in 316L or equivalent stainless steel.

Product wetted elastomers of USP Class VI EPDM, NBR, FPM all FDA conforming. Also PTFE for chemical applications.

## Weight

	Bare Shaft Pump (lbs.)	
	Horizontal porting	Vertical porting
SRU1N	33	35
SRU1W	37	40
SRU2N	62	66
SRU2W	64	68
SRU3N	117	123
SRU3W	123	130
SRU4N	231	245
SRU4W	243	256
SRU5N	335	335
SRU5W	353	353
SRU6/N	573	573
SRU6W	584	584

## Shaft Seal Options

- Single or single flush/quench (steam barrier for aseptic application) R90 or Hyclean type mechanical seals.
- Double Hyclean or R90 type mechanical seal for flush.
- Packed gland (unflushed or flushed versions).

## Materials for Mechanical Seals

Carbon/Stainless steel, Tungsten Carbide/Tungsten Carbide (R90 only), Silicon Carbide/Silicon Carbide or variations of these materials to suit fluid being pumped and/or application requirements. (N.B. Material variants are not available on all R90 or Hyclean seal types)

## Pump Sizing

In order to correctly size a rotary lobe pump some essential information is required. Provision of this information listed below enables our Customer Support personnel to obtain the optimum pump selection.

## Product/Fluid Data

- Fluid to be pumped
- Viscosity
- SG/Density
- Pumping temperature, minimum, normal and maximum
- Cleaning in Place temperature(s), minimum, normal and maximum

## Performance Data

- Flow rate, minimum, normal and maximum
- Discharge head/pressure (closest to pump outlet)
- Suction condition

## Standard Specification Options

- Tri-clamp inlet and outlet ports standard
- Specification of inlet and outlet ports (Screwed male to BSP, DIN11851, Rdg, SMS, ISS/IDF, RJT, IAMD/3A, or Flanged to BS4504/DIN2533, ASA/ANSI 150, BS10E and other standards)
- Rotorcase Cover with integral Pressure Relief Valve
- Heating/Cooling Saddle Jackets for Rotorcase and Jacket for Rotorcase Cover (not available when relief valve fitted)
- Bi-lobe Rotors in stainless steel and non-galling alloy.
- Electropolished product wetted components
- Complete pump unit comprising: Pump + Stainless Steel Baseplate + coupling with guard + Geared electric motor suitable for (or supplied with) frequency speed control or manual variable speed drive (advise motor enclosure and electrical supply).

## Working Principle

The positive displacement of the SRU pump is provided by non-contacting, contra rotating tri-lobe or bi-lobe rotors within a fully swept pump chamber. All SRU pumps are capable of bi-rotational flow without modification.

Fig. 1

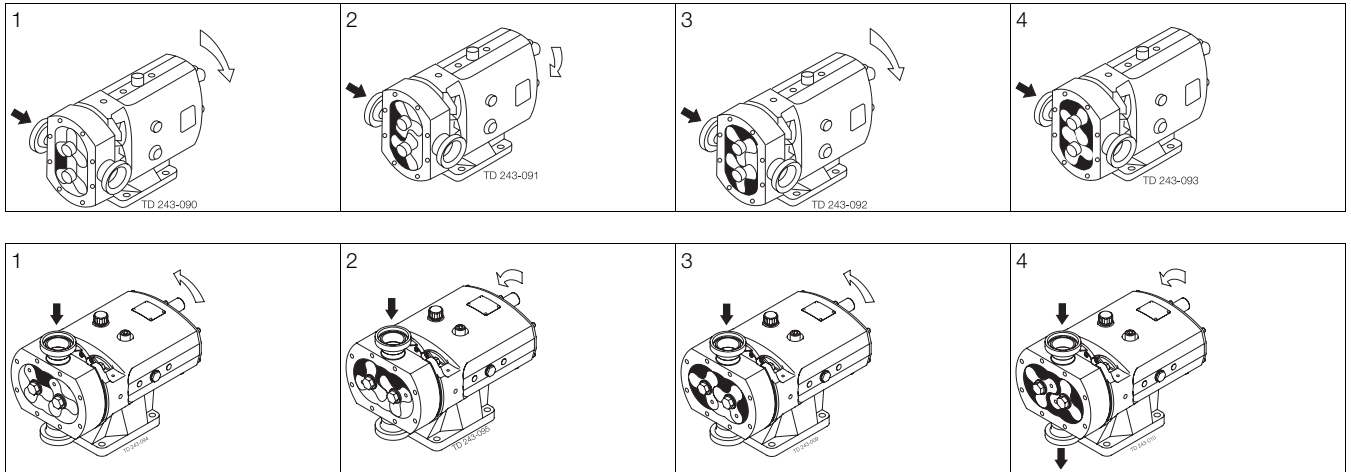

## Flows/Pressures/Connections

SRU Series	Build Selection			SRU Model	Displacement			Inlet and Outlet Connection Size				Differential Pressure (see note 1)		Maximum Speed
	Pump Head Code	Gear-box	Shaft		Litres/rev	Imp gall/ 100 rev	US gall/ 100 rev	Sanitary		Enlarged		bar	psi	rev/min
								mm	in	mm	in			
1	005	L or H	D	SRU1NLD	0.053	1.17	1.4	25	1	-	-	8	115	1000
	008	L or H	D	SRU1WLD	0.085	1.87	2.25	25	1	40	1.5	5	75	1000
2	013	L or H	S	SRU2NLS	0.128	2.82	3.38	25	1	40	1.5	10	145	1000
	013	L or H	D	SRU2NLD	0.128	2.82	3.38	25	1	40	1.5	15	215	1000
	018	L or H	S	SRU2WLS	0.181	3.98	4.78	40	1.5	50	2	7	100	1000
3	018	L or H	D	SRU2WLD	0.181	3.98	4.78	40	1.5	50	2	10	145	1000
	027	L or H	S	SRU3NLS	0.266	5.85	7.03	40	1.5	50	2	10	145	1000
	027	L or H	D	SRU3NLD	0.266	5.85	7.03	40	1.5	50	2	15	215	1000
	038	L or H	S	SRU3WLS	0.384	8.45	10.15	50	2	65	2.5	7	100	1000
	038	L or H	D	SRU3WLD	0.384	8.45	10.15	50	2	65	2.5	10	145	1000
4	055	L or H	S	SRU4NLS	0.554	12.19	14.64	50	2	65	2.5	10	145	1000
	055	L or H	D	SRU4NLD	0.554	12.19	14.64	50	2	65	2.5	20	290	1000
	079	L or H	S	SRU4WLS	0.79	17.38	20.87	65	2.5	80	3	7	100	1000
	079	L or H	D	SRU4WLD	0.79	17.38	20.87	65	2.5	80	3	15	215	1000
5	116	L or H	S	SRU5NLS	1.16	25.52	30.65	65	2.5	80	3	10	145	600
	116	L or H	D	SRU5NLD	1.16	25.52	30.65	65	2.5	80	3	20	290	600
	168	L or H	S	SRU5WLS	1.68	36.95	44.39	80	3	100	4	7	100	600
	168	L or H	D	SRU5WLD	1.68	36.95	44.39	80	3	100	4	15	215	600
6	260	L or H	S	SRU6NLS	2.60	57.20	68.70	100	4	100	4	10	145	500
	260	L or H	D	SRU6NLD	2.60	57.20	68.70	100	4	100	4	20	290	500
	353	L or H	S	SRU6WLS	3.53	77.65	93.26	100	4	150	6	7	100	500
	353	L or H	D	SRU6WLD	3.53	77.65	93.26	100	4	150	6	15	215	500

S - Stainless Steel

D - Duplex Stainless Steel

### Note 1.

These pressure ratings may vary for pumps with certain threaded connections.

## Dimensions

### Horizontally ported

- A1 denotes sanitary port dimension
- A2 denotes enlarged port dimension
- M1 denotes standard port dimension for superseded range.
- M2 refers to enlarged or sanitary port.

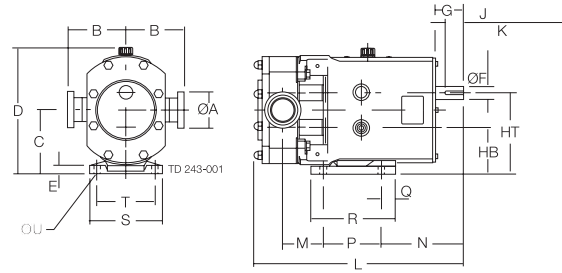

All dimensions in inches except where noted

PUMP	A1	A2	B	C	D	E	F (mm)	G	HB	HT	J	K (mm)	L	M1	M2	N	P	Q	R	S	T	U
SRU1N	1.00	-	3.74	3.56	7.44	0.39	16	1.57	2.68	4.45	1.18	5	11.22	1.81	1.65	4.88	3.15	0.39	3.94	3.94	3.15	0.39
SRU1W	1.00	1.50	3.74	3.56	7.44	0.39	16	1.57	2.68	4.45	1.18	5	11.61	1.99	1.89	4.88	3.15	0.39	3.94	3.94	3.15	0.39
SRU2N	1.00	1.50	4.13	4.53	9.17	0.59	22	1.97	3.35	5.71	1.26	6	13.35	2.50	2.36	5.16	3.94	0.75	5.20	4.88	3.94	0.47
SRU2W	1.50	2.00	4.13	4.53	9.17	0.59	22	1.97	3.35	5.71	1.26	6	13.70	2.62	2.48	5.16	3.94	0.75	5.20	4.88	3.94	0.47
SRU3N	1.50	2.00	4.92	5.41	10.75	0.71	28	2.40	3.94	6.89	1.57	8	17.20	3.41	3.25	6.93	4.92	1.18	7.13	6.06	4.92	0.55
SRU3W	2.00	2.50	4.92	5.41	10.75	0.71	28	2.40	3.94	6.89	1.57	8	17.72	3.72	3.43	6.93	4.92	1.18	7.13	6.06	4.92	0.55
SRU4N	2.00	2.50	5.91	6.42	12.80	0.79	38	3.15	4.53	8.31	2.48	10	21.30	4.29	3.98	8.82	5.91	1.38	7.95	7.24	5.91	0.55
SRU4W	2.50	3.00	5.91	6.42	12.80	0.79	38	3.15	4.53	8.31	2.48	10	21.97	4.65	4.33	8.82	5.91	1.38	7.95	7.24	5.91	0.55
SRU5N	2.50	3.00	6.89	7.68	14.80	0.79	45	4.33	5.31	10.04	2.76	14	24.68	4.17	3.82	10.98	7.09	1.38	10.83	8.27	7.09	0.55
SRU5W	3.00	4.00	6.89	7.68	14.80	0.79	45	4.33	5.31	10.04	2.76	14	25.59	4.61	4.25	10.98	7.09	1.38	10.83	8.27	7.09	0.55
SRU6N	4.00	4.00	7.48	8.86	16.89	0.79	48	4.33	6.10	11.61	2.76	14	29.45	5.30	4.90	10.47	10.24	1.57	14.57	8.66	7.48	0.55
SRU6W	4.00	6.00	7.48	8.86	16.89	0.79	48	4.33	6.10	11.61	2.76	14	30.59	5.79	5.51	10.47	10.24	1.57	14.57	8.66	7.48	0.55

### Vertically ported

- A1 denotes sanitary port dimension
- A2 denotes enlarged port dimension
- M1 denotes standard port dimension for superseded range.
- M2 refers to enlarged or sanitary port.

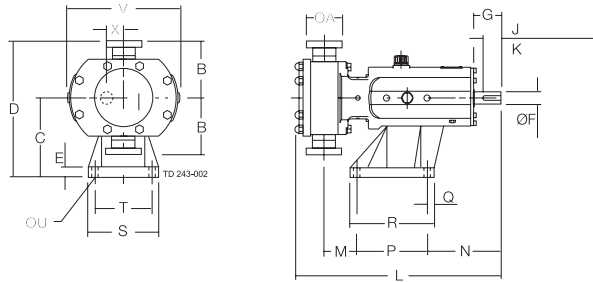

All dimensions in inches except where noted

PUMP	A1	A2	B	C	D	E	F (mm)	G	J	K (mm)	L	M1	M2	N	P	Q	R	S	T	U	V	X
SRU1N	1.00	-	3.74	4.45	8.19	0.59	16	1.57	1.18	5	11.22	2.09	1.93	4.61	3.15	0.87	4.49	4.09	3.15	0.39	7.05	0.89
SRU1W	1.00	1.50	3.74	4.45	8.19	0.59	16	1.57	1.18	5	11.61	2.26	2.17	4.61	3.15	0.87	4.49	4.09	3.15	0.39	7.05	0.89
SRU2N	1.00	1.50	4.13	5.79	9.92	0.59	22	1.97	1.26	6	13.35	2.78	2.64	4.88	3.94	0.47	4.88	4.88	3.94	0.47	8.62	1.18
SRU2W	1.50	2.00	4.13	5.79	9.92	0.59	22	1.97	1.26	6	13.70	2.89	2.76	4.88	3.94	0.47	4.88	4.88	3.94	0.47	8.62	1.18
SRU3N	1.50	2.00	4.92	6.89	11.81	0.87	28	2.40	1.57	8	17.20	2.81	2.66	6.34	6.10	0.59	7.28	6.10	4.92	0.55	9.96	1.48
SRU3W	2.00	2.50	4.92	6.89	11.81	0.87	28	2.40	1.57	8	17.72	3.13	2.83	6.34	6.10	0.59	7.28	6.10	4.92	0.55	9.96	1.48
SRU4N	2.00	2.50	5.91	8.39	14.29	0.98	38	3.15	2.48	10	21.30	3.39	3.07	7.76	7.87	0.67	9.21	7.24	5.91	0.55	12.09	1.89
SRU4W	2.50	3.00	5.91	8.39	14.29	0.98	38	3.15	2.48	10	21.97	3.74	3.43	7.76	7.87	0.67	9.21	7.24	5.91	0.55	12.09	1.89
SRU5N	2.50	3.00	6.89	10.10	16.99	1.18	45	4.33	2.76	14	24.68	3.96	3.60	10.39	7.87	0.79	9.45	8.66	7.09	0.55	13.58	2.36
SRU5W	3.00	4.00	6.89	10.10	16.99	1.18	45	4.33	2.76	14	25.59	4.41	4.06	10.39	7.87	0.79	9.45	8.66	7.09	0.55	13.57	2.36
SRU6N	4.00	4.00	7.48	11.61	19.09	1.18	48	4.33	2.76	14	29.45	5.28	4.88	10.51	10.24	0.79	11.81	9.84	8.27	0.55	15.75	2.76
SRU6W	4.00	6.00	7.48	11.61	19.09	1.18	48	4.33	2.76	14	30.59	5.75	5.47	10.51	10.24	0.79	11.81	9.84	8.27	0.55	15.75	2.76

PD66342US 2005-09

The information contained herein is correct at the time of issue, but may be subject to change without prior notice.

---

**How to contact Alfa Laval**

Contact details for all countries are continually updated on our website. Please visit [www.alfalaval.com](http://www.alfalaval.com) to access the information direct.