

Series 900 - Wafer Type



Ductile Iron Body, 316 SS Disc, Wafer Type Butterfly Valve



Description

Jomar butterfly valves are standard with epoxy coated, ductile iron bodies, and also phenolic backed cartridge type seats. Accompanied by precision machined 316SS disc, and 410SS stem, they offer lower operating torques, bubble tight shut-off, and extended seat life. Jomar butterfly valves are bi-directional and suited for dead end service. Jomar butterfly valves are standard with an extended neck, which makes them ideal for applications where insulation is required. Jomar butterfly valves are manufactured to ISO 5211 standards and have direct mount capabilities.

Specifications

Designed for commercial and industrial applications up to 225 PSI. Easily accepts actuator with ISO 5211 mounting flange.

- Available in EPDM, PTFE, Buna, or Viton seats
- Meets API 609 & MSS SP-67
- Seat to flange seal eliminates the need for flange gaskets
- Dead end service (single flange)
- Epoxy coated finish
- Ideal for mounting pneumatic/electrical actuators
- Square stem for direct mount

Accessories

- 10 position locking lever handle
- Gear operators
- Electrical and pneumatic actuators

Warranty

The Company, for a period of one year from the date of shipment, warrants each product or system of its own manufacture to the original purchaser to be free from defects in material and workmanship under normal use, service and maintenance.

Architect/Engineer approval

Job Name _____ Date _____
Model Specified _____ Quantity _____
Variations Specified _____
Customer/Wholesaler _____
Contractor _____
Architect _____

Note: Information subject to change without notice.



Jomar International Ltd.
7243 Miller Drive
Warren, MI 48092
Phone: 800-325-5690
Fax: 800-628-4194
www.jomar.com

© Copyright 2008 Printed in U.S.A.
BFW-B-0208

Series 900 - Wafer Type

Ductile Iron Body, 316 SS, Wafer Type Butterfly Valve



Description

Jomar Butterfly Valves come standard with phenolic backed cartridge type seats. Companied with precision machined 316 SS disc, offers low operating torque, bubble-tight shut-off and longer seat life. Jomar butterfly valves are bi-directional and suited for dead end service

Dimensions in Inches

Computer No.	Valve Size	A	B	C	D	E	F	G	Weight	CV
900-02DS_B	2"	6.34	3.15	1.65	1.20	.35	2.07	1.97	5.50	135
900-0212DS_B	2-1/2"	6.89	3.50	1.76	1.20	.35	2.54	1.97	7.00	220
900-03DS_B	3"	7.13	3.74	1.78	1.20	.35	3.10	1.97	8.14	302
900-04DS_B	4"	7.87	4.49	2.05	1.20	.43	4.10	2.76	10.08	600
900-05DS_B	5"	8.39	5.00	2.14	1.20	.55	4.86	2.76	15.40	1022
900-06DS_B	6"	8.90	5.47	2.20	1.20	.55	6.13	2.76	17.20	1579
900-08DS_B	8"	10.24	6.89	2.39	1.77	.67	7.98	4.02	29.00	3136
900-10DS_B	10"	11.50	7.99	2.58	1.77	.87	9.87	4.02	42.20	5340
900-12DS_B	12"	13.27	9.53	3.03	1.77	.87	11.88	4.02	71.50	8250

Part Name	Material	Temperature F	Temperature C
Seat (Soft Seal)	Buna-N (NBR)	+10 to 180	-12 to 82
	Buna-N, Food Grade	+10 to 180	-12 to 82
	EPDM	-30 to 250	-35 to 121
	EPDM, Food Grade	-30 to 225	-35 to 107
	EPDM, Heat-Resistant	+30 to 300	-2 to 150
	Viton	+10 to 275	-12 to 135
	Viton, High Temp	+10 to 400	-12 to 204
	Neoprene	+20 to 200	-7 to 93
	Hypalon	0 to 275	-18 to 135
	Silicon	-70 to 425	-57 to 218
	PTFE over EPDM	-20 to 250	-29 to 121
	PURE PTFE	-100 to 400	-74 to 204

Material Specification

No.	Part Name	Materials
1	Body	Ductile Iron
2	Seat	EPDM / PTFE / BUNA / VITON
3	Lower Stem	410 Stainless Steel
4	Disc	316 Stainless Steel
5	Upper Stem	410 Stainless Steel
6	Locating Pin	Cast Steel
7	Bushing	PTFE
8	O-ring	EPDM

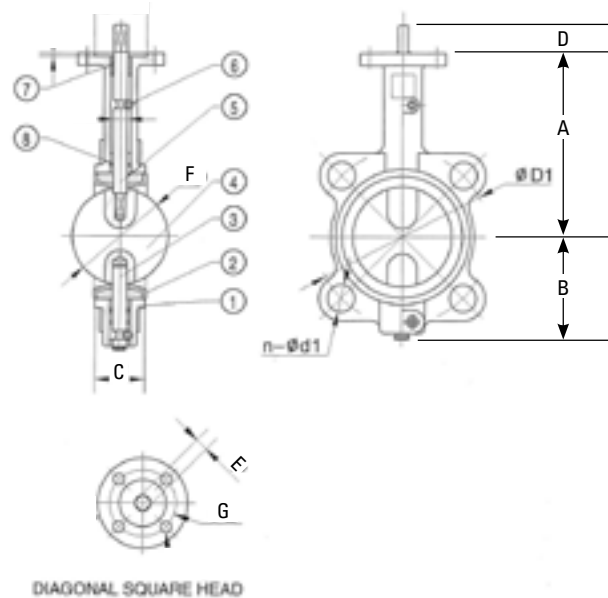

DIAGONAL SQUARE HEAD

Size	Flow in Gpm @ 1PSI P @ Various Disc Angles								
	10°	20°	30°	40°	50°	60°	70°	80°	Full 90°Open
2"	0.1	5	12	24	45	64	90	125	135
2.5"	0.2	8	20	37	65	98	144	204	220
3"	0.3	12	22	39	70	116	183	275	302
4"	0.5	17	36	78	139	230	364	546	600
5"	0.8	29	61	133	237	392	620	930	1022
6"	2	45	95	205	366	605	958	1437	1579
8"	3	89	188	408	727	1202	1903	2854	3136
10"	4	151	320	694	1237	2047	3240	4859	5340
12"	5	234	495	1072	1911	3162	5005	7505	8250

Note: Information subject to change without notice.



Jomar International Ltd.
7243 Miller Drive
Warren, MI 48092
Phone: 800-325-5690
Fax: 800-628-4194
www.jomar.com

© Copyright 2008 Printed in U.S.A.
BFW-B-0208